



# JOURDAIN

N°1 MONDIAL DU TUBULAIRE BOVIN

JUNE 2024



NEW PRODUCTS

"We are proud to present you with our latest new products, the fruit of close cooperation between our dealers and the needs expressed by farmers. We hope that the functions proposed will help you maximize your daily operations."

always  
**INNOVATING**

## NEW FILLING FLAP

**■ LIMITING LOSS OF FOOD FOR BUCKET FILLING**



The 2.50 metre feeder in our range now features two filling flaps for a capacity of 1,200 litres feed.

To limit waste, two flaps have been added which can be opened during filling, serving as funnels to limit feed waste and ensure effective bucket filling.

These two filling flaps can be purchased separately to ensure easy assembly on your older feeder models. You can benefit from this new feature without having to invest into completely new equipment.

# "MOBILE" CALF PENS

## ■ PRACTICALITY AND SAFETY

Our latest innovation is designed to meet the needs of your nursery with unequalled practicality. Whether in single or dual version, our pens can be fitted with castors for optimum mobility. They are perfectly suited for hosting calves up to six weeks of age.

You can also decide to lay them on the ground. Each unit comprises a complete initial pen, which can be expanded by means of extensions creating additional spaces.

Our carefully built pens feature three panels in virgin polypropylene for total sealing. Two of these panels form the sides, but they can also be removed to create a configuration for two calves while one rear panel remains fixed.

The façade remains easily accessible by means of a locking pin. It is fitted with two manual headlocks to control access. Fitted with two 28.5 cm diameter folding bucket holders, our pens are supplied with two buckets, to which an optional suckling bucket can be added. This product features our patented slip-proof slats, raising by a joint fastened to the wall.

*always*  
**INNOVATING**

## PATENTED

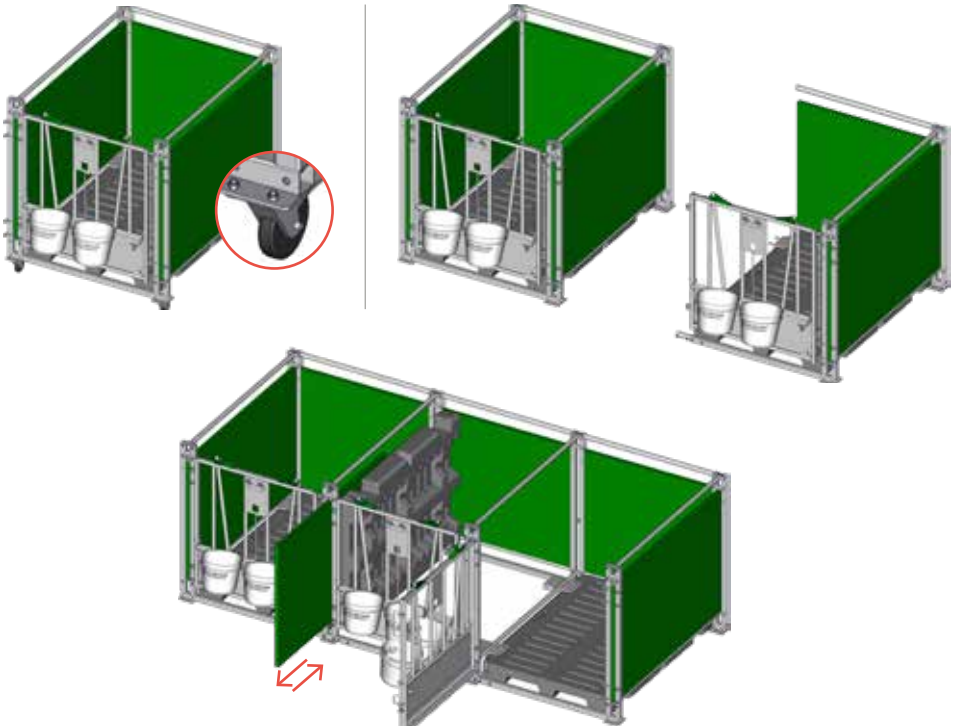

## EX 2 BARRIER

### RELIABLE AND SECURED CLOSING

With our EX 2 range of extending barriers, we offer a versatile and rugged solution to meet your needs for calf service and free service gate. This barrier comprises a rear section in 60 mm tube and a front section in 49 mm tube, hence offering exceptional sturdiness and durability.

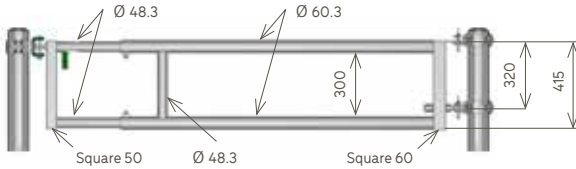
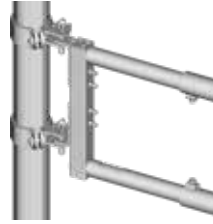

#### EX 2 AUTOLOCK GATE

**BA1550** L. 1/2 m

**BA1551** L. 2/3 m

**BA1552** L. 3/4 m

**BA1553** L. 4/5 m

**BA1554** L. 5/6 m

The front barrier features an AUTOLOCK built into the rail. The front square is drilled to be fitted with the adaptation plates (SAC552). This feature enables this barrier to be fitted as a panel for free-service use for calves.

The rear section is designed to be fitted with a lug rod for a height adjustment, guaranteeing optimum operation of the barrier. This feature enables the barrier to be slammed thanks to our market-acknowledged patented SURLOCK bracket.

## EX 3 MILKY BARRIER

### UNAVOIDABLE FOR YOUR MILK FARMING

Designed specifically for buildings sheltering milking cows, our range of EX 3 Milky extending barriers offer exceptional performance and incomparable versatility. Composed of 3 tubes, this barrier is perfectly suited for the passage of manure vacuuming robots under the barrier, while providing effective protection of the doors of buildings and the creation of service gates. The EX 3 Milky barrier is supplied with an AUTOLOCK for secured closing, but it can also be fitted with an optional chain to provide basic fastening on a post or with another barrier.

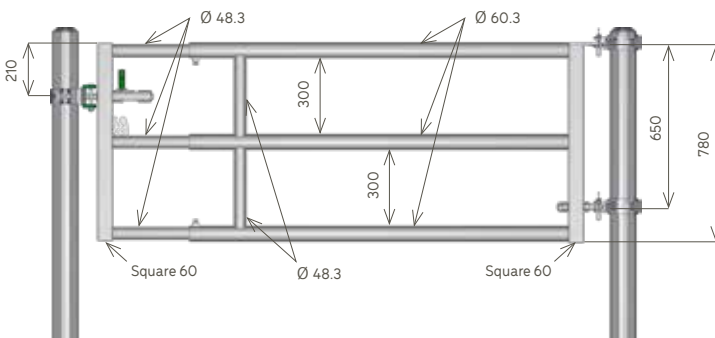

#### MILKY EX 3 AUTOLOCK DOOR

**BM0336** L. 1/2 m

**BM0337** L. 2/3 m

**BM0338** L. 3/4 m

**BM0339** L. 4/5 m

**BM0340** L. 5/6 m

# SEMI-BARRED FIXED FIELD BARRIER

## OPTIMUM PROTECTION

Our new range of fixed field barriers 50 x 50 mm meshed bars to prevent young animals, mainly lambs and goats, from crossing the barrier.

Each barrier includes an AUTOLOCK. Use a padlock to prevent the barrier from being opened for additional peace of mind and protect your pens.

Designed to last, this fixed field barrier is not adjustable and requires posts to be anchored in the presence of the barrier. The dimensions correspond to axis/post axis lengths of 102 mm.

### SEMI-BARRED FIXED FIELD GATE

<b>BF0012</b>	L. 1.19 m
<b>BF0018</b>	L. 1.79 m
<b>BF0021</b>	L. 2.14 m
<b>BF0027</b>	L. 2.74 m
<b>BF0032</b>	L. 3.23 m
<b>BF0037</b>	L. 3.73 m
<b>BF0042</b>	L. 4.18 m
<b>BF0047</b>	L. 4.69 m
<b>BF0051</b>	L. 5.13 m
<b>BF0061</b>	L. 6.13 m

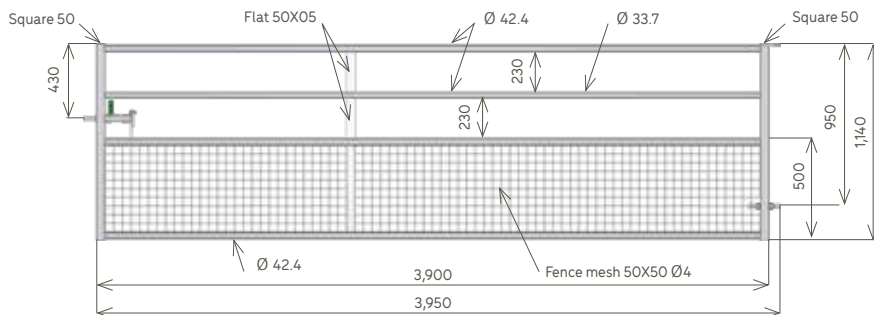

The "Made in France" logo is a label that manufacturers or distributors may attach to their products under certain conditions in order to attest to their French origin. For JOURDAIN, this definition of "Made in France" is not enough, which is why we have created our own logo. The French manufacture of our products guarantees total control of design, manufacture, quality control and logistics in house, on our Esrennes site (in the central French department of Loiret).



### Read our CGUs!

The General Conditions of Use (CGU) are essential to understanding our products. They describe the assembly and use instructions.



### Catalogue T39

Over 850 products vital for your farm. To be discovered here:

